

ecosmart[™]
Fire

LEADERS OF THE GLOBAL BIOETHANOL FIREPLACE EVOLUTION

LOOK BOOK



ISSUE / 2

WHETHER INDOOR OR OUT, COMMERCIAL
OR RESIDENTIAL, THE UNIQUELY VERSATILE
ECOSMART FIRE PROVIDES THE FOUNDATION
– THE CREATIVE FREEDOM TO EXPRESS
YOURSELF THROUGH THE ART OF FIRE



DRIVING DESIGN TRENDS

IT'S INCREASINGLY OBVIOUS THAT THE ECOSMART FIRE CONTINUES TO DRIVE AND INSPIRE DESIGN TRENDS AROUND THE WORLD.

And what's defining the next generation of EcoSmart Fire designs is simple. It's all about creation: creating bespoke fireplaces and fireplace settings using the uniquely versatile EcoSmart Fire models as the foundation.

The iconic EcoSmart Fire's ever-evolving range constantly redefines and challenges the concept of the bioethanol fireplace. It's evident in the way the architectural and design world are embracing the creative freedom provided by bioethanol and the diversity of the EcoSmart Fire range, and how they're increasingly adding this staple tool to their repertoire. The result? New ways of expressing themselves through the art of fire, to the benefit and enjoyment of their customers.

*Front Image:
The Westin (AUS)*

*Opposite image:
Hippo Creek African Grill (AUS)*

And not only is the EcoSmart Fire inspiring custom-made designs, it's also providing the spark for original models. Renowned Barcelona based designer Hiroshi Tsunoda is the latest to partner with The Fire Company to create a new EcoSmart Fire – the award-winning outdoor model, STIX.

FEATURED STORIES

1/ FLAGSHIP FIRE

The Allianz Arena in Munich is the location of an amazing new Cooking Lounge. And it's not just the clients' appliances and technology that are making a statement.

2/ OUTDOOR FOCUS

Australian TV personality and celebrity gardener Jason Hodges fondly remembers sitting around an open fire as a child. Today Jason loves working with EcoSmart Fires to set the scene for many of his landscape designs.

3/ OUT OF AFRICA

Cleverly tailored EcoSmart Fire burners are helping set the scene for a vibrant new African grill style restaurant in Perth.

4/ SPARK OF DESIGN GENIUS

Breathing new life into an old fireplace at the acclaimed May Fair Bar in London has been easily achieved with a series of BK5 EcoSmart Fire Burners.

5/ WARM REJUVENATION

An iconic Brisbane hotel has been given a makeover – and the EcoSmart Fire XL900 provided the design freedom the architects were seeking to achieve their aims.

6/ JUST LOUNGIN'

An award-winning five star Sydney hotel has created an intimate lounge bar complete with an open fireplace that's providing a touch of 'home' for the guests.

7/ SUITE DREAMS

A five-star all-suite hotel in London is setting a new benchmark in luxury accommodation – with EcoSmart Fires providing distinct focal points.

8/ VISIBLY TRANSFORMED

Washington DC's Equinox restaurant has a stylish new feature that has a clever dual purpose.

9/ HEART OF THE HOME

The slick design of a refurbished London apartment has been perfectly complemented by an EcoSmart Fire 1200SS Firebox.

10/ CLASSICAL CONTEMPORARY

Recreating the timeless, classical beauty of European interiors has been facilitated by EcoSmart Fire Burners for a Melbourne design house.



1/

Series of BK5 Burners

FLAGSHIP FIRE

AS THE NUMBER ONE BRAND FOR HOUSEHOLD APPLIANCES IN THE GERMAN HOME MARKET AND EUROPE'S LEADING BUILT-IN KITCHEN APPLIANCE BRAND, SIEMENS IS SYNONYMOUS WITH INNOVATION, FIRST-CLASS DESIGN AND OUTSTANDING PERFORMANCE. IT'S WITH THAT IN MIND THAT INTERIOR DESIGNER ANGELIKA LUIBLE-GARBOLDI FROM BAU+DESIGN DESIGNED THE FLAGSHIP SIEMENS COOKING LOUNGE IN MUNICH'S ALLIANZ ARENA.

Set high above the playing field, the smart 160sqm lounge is designed to showcase Siemens' latest kitchen technologies, and has myriad uses, such as a relaxation area, conferences, product launches, cooking demonstrations or classes, and photo shoots – or to watch the football games below in a stylish, comfortable space.

And at the heart of the Cooking Lounge are an expansive stone chimney and three EcoSmart Fire BK5 Burners.

The EcoSmart Fire Burners were instrumental in producing a convivial atmosphere, says interior designer Angelika.



“A traditional fireplace simply didn’t integrate seamlessly into the Cooking Lounge area,”

Angelika explains.

“The EcoSmart Fire solution has delivered the ambience of a real open fire without the mess or hassle.”

In the first instance, Angelika came up with the concept of the central chimney, and as there was no gas connection and other fire sources weren’t possible, she chose the EcoSmart Fire Burners. She used three in the design to balance the length of the chimney.

“EcoSmart was a clever design alternative for this stylish and contemporary space where people come to connect, relax and be entertained,” Angelika says. “The strong, bold yellow flame is mesmerising, but it’s also free from smoke, mess and odour. And the fireplace offers the elegance and the style that VIP guests have come to expect.”

The chimney and EcoSmart Fires also help delineate the lounge and conference / cooking areas, with the burners set into a long, raised benchtop incorporating non-burning timber, metal and concrete. “The whole solution was both practical and affordable. The fire is a real drawcard for VIP guests and provides a unique atmosphere,” Angelika adds.





Jason Hodges
www.greenartgardens.com.au

2/ Loft OUTDOOR FOCUS

FOR AUSTRALIAN TV PERSONALITY AND CELEBRITY GARDENER JASON HODGES, SITTING AROUND AN OPEN FIRE INSTANTLY EVOKES HAPPY CHILDHOOD MEMORIES. WHETHER IT'S TOASTING MARSHMALLOWS AROUND A CAMPFIRE OR WATCHING DAD COOK DINNER ON THE BARBEQUE, JASON SAYS FIREPLACES CONNECT TO SOMETHING DEEP WITHIN.

"I don't know what it is, but an open fire is incredibly mesmerising and immediately conjures up those romantic feelings of sitting at a candlelit table with a loved one or kicking back around a campfire with friends," he says. "So I guess you can be an Aussie bloke and a romantic fool at the same time!"

Open fireplaces have featured extensively in Jason's landscaping designs over the past decade, to less than impressive effect. Wood fires are unpredictable and dirty, and gas fireplaces are hard to locate outside without a dedicated gas connection. And as Jason says, "they don't have a natural looking flame."

Fortunately, it was a chance meeting on his Better Homes & Gardens TV show gave Jason the solutions he was looking for.

"A few years ago, I presented a segment on outdoor heating and EcoSmart Fire was clearly

the top-of-the-range," he recalls. "I was immediately impressed by its versatility and stunning architectural design, how easily it switched on and off, and the fact that there was no smell whatsoever the entire time it was in use."

In addition to EcoSmart Fire's signature clean lines and timeless design, Jason is also a fan of the brand's environmental sensitivity. "It really does burn as clean as a candle and not only do you avoid paying astronomical prices for timber but you help save the environment too."

In 2010, Jason and his Greenart Gardens design team won 'Gold Show Garden' at the Melbourne International Flower and Garden Show, which featured The EcoSmart Loft Fire Screen with AB3 Burner combination kit integrated into a timber benchtop, and three slim fireboxes set into a sandstone feature wall.

"When it came to setting a scene and drawing people in and making them feel comfortable, The EcoSmart Fire was the one and only choice," Jason says.

"The Fire Company clearly spends a lot of money testing their products, which gives me enormous confidence in not only using them at home but also recommending them to my clients. Even the quality of the stainless steel is impressive – I've had my EcoSmart Fire for two years and it looks as good as the day I bought it."



3/

Series of XS340 Burners

OUT OF AFRICA

IT'S ONE OF PERTH'S NEWEST RESTAURANTS – AND IT'S ALREADY MAKING ITS NAME NOT JUST FOR THE UNIQUE DINING EXPERIENCE, BUT ALSO FOR THE VIBRANT AND EXOTIC INTERIOR. HIPPO CREEK AFRICAN GRILL IN SUBIACO IS ALL ABOUT OPEN FIRE COOKING – WOOD-FIRED CHAR GRILL – WHICH HARKS BACK TO NOMADIC HUNTER GATHERERS. AND AS PART OF THE INTERIOR DESIGN, THE SOUTH AFRICAN RESTAURATEUR WANTED AN OPEN FIREPLACE WHICH WAS IN KEEPING WITH THE THEME OF HIPPO CREEK.

“Back in South Africa, our client used a barbecue called a braai,” explains Mike Booth from Bremick Design + Build. “South Africans love meat cooked with flames and charcoal. It’s why they wanted to use fire at the entry of the restaurant to really set the scene.”

Three EcoSmart Fire Burners were incorporated into a 20-gallon barrel which had been cut in half, welded together and braced to hold toughened glass panels into position. Black river stones were placed around the burners and Axolotl paint was then used to make the fireplace look rustic.

The client’s brief was to create a modern African restaurant which, above all, had a wow factor. Having already seen and liked the entire EcoSmart Fire range, they decided an open fireplace would be an ideal fit.



"We wanted a high, colourful flame which could be contained (for safety reasons) and at the same time be highly visible, and be a big attraction," explains Mike. "Bigger is better! The burners achieve that and provide a wall of flame across the entire fire pit."

"EcoSmart Fire pretty much ticked all the boxes. We didn't need to look anywhere else – we found exactly what we were looking for."

There were a number of other benefits of using the EcoSmart Fire Burners: "Simplicity, ease of installation, the high level of technical information," Mike adds. "We were more than satisfied."

Having installed the EcoSmart Fire Burners into the Hippo Creek restaurant, Bremick Design + Build has just specified EcoSmart Fire for the new beachside development – Mirvac's flagship – being developed in Western Australia.

Bremick Design + Build is constructing a restaurant and bar, and will incorporate two EcoSmart Fires, which will back onto the bar section.

"I wouldn't hesitate in recommending EcoSmart Fire for future projects," says Mike.

"We use [EcoSmart Fire] as a point of differentiation for a client's dining area, depending on the style and theme of the restaurant."

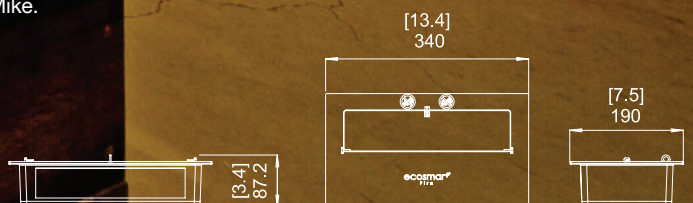

4/

Series of BK5 Burners

SPARK OF DESIGN GENIUS

A SERIES OF BK5 BURNERS FROM ECOSMART FIRE HAS BREATHED NEW LIFE AND AN INTIMATE ATMOSPHERE INTO A FORMER GAS FIREPLACE IN CENTRAL LONDON'S STYLISH MAY FAIR BAR – ACCLAIMED AS THE BEST HOTEL BAR IN LONDON.

THE OWNERS OF THE RADISSON HOTEL'S MAY FAIR BAR SOUGHT TO REPLACE A DEFECTIVE 1.2M-LONG GAS FIREPLACE WITH ONE THAT WAS BOTH FUNCTIONAL AND A CONTEMPORARY DESIGN SHOWPIECE.

www.themayfairhotel.co.uk

According to Wayne Coddington from the Radisson, the disused gas fireplace had a problematic flue comprised of several straight angles that prevented emissions from being properly extracted.

“We needed a stylish solution that could be installed within three weeks, with minimal disruption to the continuous flow of clientele. EcoSmart Fire Burners offered unlimited design flexibility and emission-free ethanol fuelled heating.”

And with the 2012 London Olympic Games moving ever closer, the hotel's owner wanted to ensure the bar would have the proper wow factor that would please the high profile clientele. Wayne says the EcoSmart Fire has already become a major drawcard for May Fair Bar patrons.

“The resulting design certainly exceeded our expectations. Its powerful, bright yellow flame is an attractive drawcard. May Fair Bar guests cross the full length of the bar to come and sit next to the fireplace,” he says.

The popularity of the EcoSmart Fire in the May Fair bar also influenced the Radisson's decision to install an XL900 Burner in the refurbished Palm Beach Casino, an exclusive casino and poker club located in the May Fair's former Grand Art Deco Ballroom. Casino customers have been equally drawn to the fireplace's attractive flame and warmth.



5/
XL900

WARM REJUVENATION

FOR ALMOST 30 YEARS, THE CALAMVALE HOTEL IN THE SOUTHERN SUBURBS OF BRISBANE, AUSTRALIA HAS BEEN A FAVOURITE WITH LOCALS. WITH THE PASSING OF THE YEARS, THE HOTEL WAS IN NEED OF A MAKEOVER, AND ARCHITECTURAL FIRM BRAND + SLATER WAS COMMISSIONED TO REFURBISH THE INTERIORS, REDEFINE THE EXISTING OUTDOOR TERRACE AND ADD A DISTINCTIVE EXTENSION TO MODERNISE THE HOTEL.

“Our challenge was to create a unique bar and dining experience that articulated the indoor outdoor connection,”

BRAND + SLATER'S
JESSICA HERSCH

“And as part of the design we needed an elegant linear burner that could be set into a custom-designed open fireplace.”

After considering several gas burner options, the design team discovered the EcoSmart Fire XL Burner. They elected to join together two EcoSmart Fire XL Burners, providing a 1.5m linear flame.

“To warm up both literally and aesthetically the voluminous interior, an open fireplace that virtually hovered over the indigenous garden was incorporated,” Jessica explains.

“We had some issues with trying to design a flue to suit the interior space, and the clean-burning fuel option eliminated the need for an unsightly flue which would distract from the simplicity of the timber clad sloping back wall. Our key design aspects were elegance, simplicity, understatement and transparency, and the XL900 epitomised these and allowed design freedom.”

The result is a sloping screen wall above the floating hearth, which is clad in striking black tiles, and the toughened glass back of the fireplace allows

glimpses into the garden beyond, further emphasising the indoor outdoor connection. “Gazing at the flames with the green foliage behind is a delight to the senses,” Jessica says.

As well as satisfying the design needs, the EcoSmart Fire has become a focal point in the hotel. “For such a voluminous space I am really impressed with the amount of heat the XL900 gives off. In winter people request tables near the fireplace for the ambience and warmth this feature provides,” says Jessica.

www.brandandslater.com.au





6/ BK5 JUST LOUNGIN'

IT WAS RECOGNISED AS AUSTRALASIA'S LEADING BUSINESS HOTEL AT THE 2010 ANNUAL WORLD TRAVEL AWARDS, AND IN RECENT TIMES THE WESTIN HOTEL IN SYDNEY HAS ADDED A TOUCH OF 'HOME' WITH THE OPENING OF ITS NEW LOBBY ROOM, A PRIVATE RETREAT FOR BUSINESS TRAVELLERS.

A key feature of the space – and the main focal point for the central sitting area – is its open fireplace, created using an EcoSmart Fire BK5 Burner with stainless steel surrounds and a toughened glass screen.

Interior designer Joseph Pang wanted to create an atmosphere akin to being in your own lounge room, which he has achieved through chocolate hues and robust textures.

The fire has been set into a special feature wall, with black gloss, random sized ceramic tiles. Flanking the fireplace are specially positioned round mirrors, with two lounge chairs situated either side of the fire.



“The EcoSmart Fire creates an intimate, warm and homely feel, similar to a lounge room environment,” explains project designer Rebecca Ng from Joseph Pang Design Consultants.

“The fire is safe, reliable, contemporary and elegant.”

The design firm also chose the BK5 Burner for its ease of maintenance and because it’s operated by bioethanol, perfect for its location within the high-rise hotel.

Additional Lobby Room design features include intelligent lighting, contemporary decor and a commissioned portrait by artist Juan Ford, a finalist for a past Archibald Award.

The new Lobby Room was part of a refurbishment and extension of the hotel’s Lobby Bar and Lounge. According to Rebecca, the complete look needed to project a stronger sense of identity whilst maintaining the hotel’s five-star image, particularly in light of the numerous new and trendy venues which had opened in the vicinity. The brief was for a space that was intimate, sophisticated and energising.

The bar was extended into a space that was previously used for retail, which allowed additional and much-needed seating. Specially positioned glass doors enable the Lobby Room to be closed for private functions or to create a more intimate space for drinks.

To unify the Lobby Room with the urban sanctuary of the Lobby Bar and Lounge, the look and feel has been blended together so the scheme of the three areas flows into one.

www.jpdc.com.au

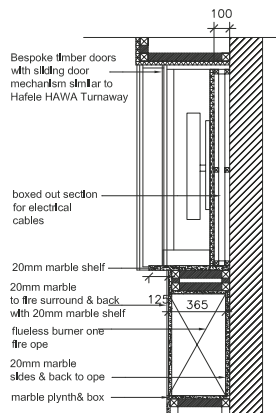

SIDE ELEVATION



7/ BK5 SUITE DREAMS

WHEN CONSULTANTS FROM DUBLIN-BASED ADI STUDIO WERE ASKED TO CREATE SIGNATURE LOOKS FOR FOUR LUXURY PENTHOUSES IN LONDON, THEY TURNED TO THE VERSATILITY OF ECOSMART FIRES.

Located in exclusive Chelsea Harbour, Wyndham Grand London Chelsea Harbour is the city's only five-star luxury all-suite hotel. Setting a new benchmark in luxury accommodation, Wyndham Grand boasts four spectacular penthouse suites that offer panoramic views of the River Thames.

Faced with no fireplace provision or gas supply, the energy efficient, renewable bioethanol-fuelled EcoSmart Fire was the standout choice.

Describing the flame as "more realistic than any other flueless fire options out there", interior designer Maria Rice says the best thing about the EcoSmart Fires was the flexibility to position them anywhere in the room. "This was certainly the best solution available, allowing us the freedom to create something that would not have been possible otherwise," she adds.

The fireplaces are designed as focal points for the penthouses' living areas, and Maria has used natural stone – predominantly marble – for the fireplace surrounds.

That each sumptuous penthouse suite pays homage to London's fashion icons says volumes about adi studio's decision to feature EcoSmart Fires. Who says you need to sacrifice style for substance?

"Our brief was to create four very different penthouse styles for what is arguably London's premier five-star hotel,"

MARIA RICE
INTERIOR DESIGNER

"We designed all aspects of the interior, so the bespoke possibilities of the EcoSmart Fire BK5 was great for us," adds Maria.

www.adistudio.ie

8/
900DB

VISIBLY TRANSFORMED

THE CLEAN, MINIMALIST AESTHETIC OF THE ECOSMART FIRE 900DB FIREBOX WAS AN ESSENTIAL INGREDIENT IN THE RECENT TRANSFORMATION AND REFURBISHMENT OF WASHINGTON DC'S AWARD-WINNING EQUINOX RESTAURANT.

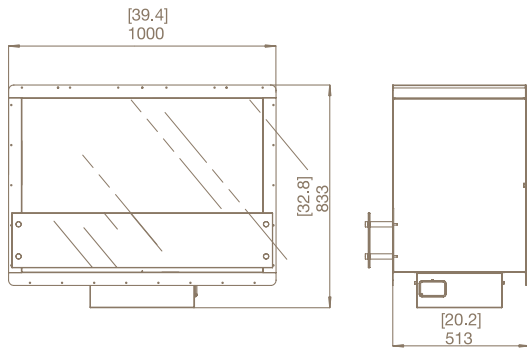

Global architecture and design firm Gensler chose the 900DB Firebox to ensure the refurbishment incorporated the very latest in sustainable fire design elements. Inserted into a stone feature wall separating the main dining room from atrium seating, the Firebox provides warmth and visibility to each space in the newly remodeled restaurant.

“The fireplace, when lit, is a visual magnet,”

GENSLER
MANAGING DIRECTOR
JORDAN GOLDSTEIN.

According to Jordan, when the fire is switched off “it serves as a stylish window between dining spaces.”

The hearth was integral to the firm’s design vision for the restaurant’s transformation, Jordan adds.

“The EcoSmart Fire Firebox allowed us to have a hearth within budget and achieve the seamlessly elegant look that we were hoping for,” he says.

“And the ease of installation allowed us to place the product quickly without the need for a typical gas connection or flue as required for a conventional fireplace. It exceeded our requirements, delivering design simplicity and elegance.”





[51.2]
1300

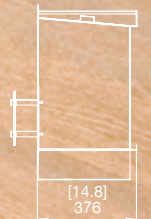

9/
1200SS

HEART OF THE HOME

A successful banker based in the centre of London, Sebastien Gianfermi and his architect-trained wife refurbished a 19th century, Regency penthouse into a sophisticated two-level family home. The iconic British style of architecture was given a much-needed modern makeover that not only breathed new life into the building but also captured the couple's signature style.

In keeping with the two-story apartment's elegant clean lines and contemporary furnishings, Sebastien chose EcoSmart Fire's 1200SS firebox for the upstairs living area.

"We needed a fireplace that not only fitted into a specially made setting but also had to accommodate a sound system in its construction," Sebastien explains.

"This particular model not only slots beautifully into the snug space, the long, elegant flame complements the slick design of the flat."

Part of EcoSmart Fire's Renovator Range, this stainless steel, zero clearance firebox includes a built-in stainless steel bench to house the EcoSmart XL900 Burner. And, like all EcoSmart Fires, the 1200SS model does not require any form of permanent fixture or fitting, such as a flue for ventilation, a permanent gas connection, or fixed utility for fuel supply.

The end result is a stunning centrepiece that seamlessly integrates into the sleek space. "We were after a wide fireplace to fit beneath a 50-inch LED screen, and which could be incorporated into the HIFI joinery," explains Sebastien.

"It fits very well. The result is fantastic."

Using environmentally friendly, bioethanol liquid fuel means there's no damaging smoke or harmful emissions, making it the perfect choice for this growing family. This also means that all of the heat generated during combustion stays in the open-plan room – resulting in an incredibly efficient heating system.

"While our decision was primarily driven by the need of a flu-less fireplace, the environmental aspect was definitely a plus," adds Sebastien.



10/^{BK5} CLASSICAL CONTEMPORARY

MELBOURNE'S DESIGN HOUSE CHATEAU COUTURE HAS A CLEAR VISION – TO RECREATE THE TIMELESS CLASSICAL BEAUTY OF EUROPEAN INTERIORS AND ARCHITECTURE BY INTEGRATING ALL THE ELEMENTS OF REVERED CLASSICAL EUROPEAN STYLE. SHOWCASING ITS SERVICES AND PROVIDING REALISTIC SETTINGS IS A CRUCIAL PART OF CHATEAU COUTURE'S MARKETING METHODS – AND ITS ELEGANT SHOWROOM PLAYS A KEY ROLE.

One of Chateau Couture's services is creating grand carved stone mantles and overmantles, and the design team sought to more realistically showcase them by establishing functional fireplaces in the showroom. Designer Sandra Traviati chose EcoSmart Fire BK5 Burners.

"The showroom is essentially a warehouse conversion, and we were unable to construct the number of chimneys required for functional fireplaces. The ability to have a clean-burning system was imperative."

Sandra has used three EcoSmart Fire Burners; one has been incorporated into one of the fireplaces, and two have been used to create a longer flame for another.

"By using the burners within custom-made grates, we were able to achieve the ambience of true fireplaces. By using two burners side by side for one of the fireplaces, it enabled us to achieve a beautifully long flame. The addition of a classical style grate and artificial logs gave us the sophisticated classical look," Sandra says.

"Functional fireplaces allowed us to create focal points within the showroom which enabled us to set up individual 'rooms' within a room. At Chateau

Couture, the fireplace with a magnificent carved limestone mantle is the epitome of sophisticated classical styling. This can now be achieved without the expense and design constraints often associated with the construction of fireplaces which require chimneys and flues etc."

The EcoSmart Fires have also allowed Chateau Couture's designers to specify mantles in a variety of rooms and any areas that require a focal point to the room.

"The ability to retrofit the EcoSmart Fires into any setting is the biggest attraction. The possibilities are endless now. EcoSmart Fires can be utilised in more classical settings, rather than only contemporary settings," Sandra adds.

"The EcoSmart Fire has a multitude of exciting design applications."

www.chateaucouture.com.au

SETTING THE BENCHMARK

Established in 2002, The Fire Company is an Australian design, innovation and export success story. Its ground-breaking range of eco-friendly bioethanol fireplaces, burners and accessories can now be found in 55 countries worldwide, across a diverse range of architectural environments.

Since its inception, The Fire Company has been at the forefront of innovation and continues to set benchmarks in design, originality, safety and sustainability. The Fire Company has pioneered the evolution of the now well-established international bioethanol fireplace industry and has led the creation of global standards and testing platforms.

As the industry becomes more regulated, EcoSmart Fire is dedicated to the ongoing support and guidance in the creation of standards and to complying with these regulatory requirements.

Bioethanol fireplaces are classified by regulations and standards as decorative fireplace appliances. Copies of test results are available to qualified applicants.

SAFETY FIRST

Mixing fire, dangerous goods and human beings is a serious business, and something we take very seriously.

As one of the first brands of "Unvented alcohol fuel burning decorative appliances" in what is now a vastly competitive global market, our award winning collection continues to set benchmarks in many arenas - from the quality of manufacturing, to the operational system and built in safety features, through to the certification achieved from various testing bodies around the world, the EcoSmart™ Fire is ever at the forefront of design, technology and safety.

EcoSmart Fires are accompanied by a proprietary operational system that ensures the safe operation of the product. Every aspect from decanting the fuel, lighting the flame, regulating the flame to extinguishing the flame has been thought through and accessorised in order to control the method of operation. As the most independently tested product on the market we offer peace of mind and have an excellent safety record.

AWARD WINNING

EcoSmart Fires were launched onto the global stage in 2004 and in the same year were awarded an Australian Design Mark. Since then, our accolades have expanded to include:

- 2011 IIDA/HD Award for Excellence (USA)
- 2011 DesignEx Best New Product (AUS)
- 2011 FINALIST Australian International Design Awards (AUS)
- 2010 International Hotel, Motel + Restaurant Show, New York
- 2010 Editor's Choice Award for Best New Product - Green Design (USA)
- 2009 Australian International Design Award (AUS)



"I really wanted to create something new with this product and thought it would be challenging for me to create an attractive centrepiece combining EcoSmart Fire with my unique design style."

Hiroshi Tsunoda, head of design firm Hiroshi Tsunoda Design and creator of the EcoSmart Fire STIX, a contemporary stainless steel fire design that evokes the mood and magnetism of a traditional campfire. The STIX is the newest addition to the Outdoor Range.

SEE MORE ONLINE

Visit www.ecosmartfire.com to see more innovative installations.

Landscape designer and celebrity gardener Jason Hodges has forged his career creating beautiful outdoor havens. Since discovering the EcoSmart Fire, Jason has used the element of fire in many of his designs - including award-winning garden displays. His passion and creativity have seen him collaborate with The Fire Company to create the EcoSmart Dish, an alfresco model specifically designed to use on a balcony deck, patio, courtyard or by a swimming pool.



THE FIRE COMPANY HEAD OFFICE

Phone +61 2 9997 3050 info@thefirecompany.com.au
www.thefirecompany.com.au

PRODUCT INFORMATION & CUSTOMER SERVICE

Contact our Customer Service Team for information about any of our products, including technical questions and pricing enquiries. info@ecosmartfire.com

COMMERCIAL & MULTI-UNIT ENQUIRIES

Contact our Commercial Sales Division to learn how to incorporate EcoSmart Fire into your next large scale development. specify@ecosmartfire.com

MEDIA ENQUIRIES

For access to our library of press releases and high resolution imagery, you can request access to our document library, or information from our media representative. media@ecosmartfire.com

**thefire
company**

