

ecosmart<sup>™</sup>  
Fire

LEADERS OF THE GLOBAL BIOETHANOL FIREPLACE EVOLUTION

# LOOK BOOK



ISSUE / 3

AN INTEGRAL PART OF A DESIGNER'S 'TOOL KIT',  
ECOSMART FIRES ARE SETTING NEW TRENDS  
IN INTEGRATION; EACH ONE PERSONALLY  
STYLED FOR A LASTING IMPRESSION.





# THE MOVE TO MODERN

FROM CONTEMPORARY SPACES TO HISTORICALLY SIGNIFICANT BUILDINGS, ECOSMART FIRES ARE BEING CLEVERLY INCORPORATED INTO THE MOST UNIQUE AND INDIVIDUAL OF ENVIRONMENTS.

For some design professionals, the design starts with EcoSmart Fire. As US-based designer Daniel Vandembark admits, “I find a home for the fire and build around it.” But incorporating EcoSmart Fires is definitely not limited to the start of a project. The sheer versatility of the collection means they can be easily incorporated into existing fireplaces or locations to revitalise or modernise a space.

German design guru Carsten Batterman, creator of the acclaimed STILHOF display studio near Munich, has used EcoSmart Fires for his studio, his own home and those of clients, because they perfectly fitted his vision “without huge adjustments.”

“EcoSmart Fires were selected because they are state of the art, beautiful in design, have high functionality and are uncomplicated in installation – plus they’re highly flexible to work with,” says Carsten.

Flexibility is not only inherent in the design of EcoSmart Fires, it’s also evidenced by the fuel – bioethanol. The global trend towards this modern fuel is helping drive the popularity of the fires, not just because of its eco credentials, but also because it further enhances the versatility of the fires.

Meaghan Wren from New York’s Meyer Davis Studio sums it up: “The ventless aspect of the system is important, because we are able to use them in places where ventilation is not possible.”

Front Image:  
Private Client, Brisbane (AUS)  
Kylie Hood Photography

Opposite image:  
EcoSmart Fire Showroom,  
Sydney (AUS)

## FEATURED STORIES

---

### 1/ REDEFINING OUTDOOR LIVING

An expansive, exposed terrace of a Brisbane high-rise apartment has been transformed into a stunning, cosy environment with different alfresco living ‘zones’ complete with open fire.

### 2/ TO INNOVATE AND INSPIRE

In creating the visionary STILHOF design studio in Germany, interior designer Carsten Batterman has included products which offer class and versatility. And EcoSmart Fire plays a leading role.

### 3/ HOME SWEET HOME

A new purpose-built, sophisticated design studio / showroom in the heart of Sydney’s design hub provides the perfect backdrop for the ever-evolving EcoSmart Fire Collection.

### 4/ FIRE & WATER

The combination of fire and water makes a dramatic entrance statement for an inner city Sydney home.

### 5/ THE NATURE OF FIRE

A customised elliptical fire which draws on the principles of the EcoSmart Zeta gives a clever illusion of a fire burning within what looks like a tree log.

### 6/ MIXOLOGY MECCA FIRES UP BERLIN

A see through EcoSmart firebox has helped define the warmth and ambience - and personality – of one of Berlin’s top 10 cocktail bars, the Shochu.

### 7/ ICONIC ARCS

The iconic outdoor amphitheatre the Hollywood Bowl in Los Angeles was the inspiration for a stunning arc-style EcoSmart Fire in an LA backyard – but its design and installation wasn’t without its challenges.

### 8/ MOVING TO MODERN

The magnificent art deco fireplace in Melbourne’s Manchester Unity Building is no longer decorative, thanks to an EcoSmart burner.

### 9/ HOME AWAY FROM HOME

A cosy, beautifully designed resident lounge in a boutique apartment hotel in New York City has an open fire with elongated flame as the centre element.

### 10/ A PORTRAIT OF LIFE

Design professional Susan Jay has a simple design philosophy: “I believe my clients’ lifestyle dictates the design,” she says. “The design is a portrait of their lifestyle.” A stunning piece of specially created fire furniture in an LA master bedroom is testament to this.





“Our clients wanted a cosy, intimate yet open space where they could sit quietly or entertain,” explains Carole Hood from Multi Span Australia Group, which undertook the design and construct project. “The design had to be modern, with an oriental flare, allowing the inside to flow out.”

The terrace, which features eagle’s nest views of Brisbane’s Storey Bridge and cityscape, has a number of distinct ‘zones’ including covered outdoor dining area, a casual seating space, barbecue area, and a covered outdoor living ‘room’, complete with a clever dual-purpose daybed (on one side) and breakfast bar (on the other side), plus leather ‘armchairs’.

Taking pride of place is a specially created fireplace which both enhances the intimacy of the space and creates a distinct focal point and beautiful illumination of the area. After considering a number of heating solutions, Multi Span chose an EcoSmart XL900 burner following a recommendation from Wrightson Stewart Interior Design, which had previously used EcoSmart Fire products.

The aesthetics of the XL burner plus versatility, functionality and eco credentials were key reasons Multi Span chose the fire.

The burner, together with stainless steel surrounds, is at the heart of a superb piece of cabinetry, created with seven types of rich-hued timber which, Carole explains, give variety of colour plus a 3-dimensional look. “It was very labour intensive, but provided a fabulous outcome,” she says.

Other elements of the cabinet are a tailor-made artwork which sits above fireplace, planter box and timber privacy screen – all of which combine to enhance the ambiance of the space and truly define the outdoor room. Grey granite has been used for the tops of the fire cabinet and breakfast bar.

The high-set position of the apartment meant a particular challenge was the sometimes gale force winds. “The glass wind shield works perfectly, thus allowing the flame to continue burning,” Carole says. “Plus a stainless steel cover was made to protect the unit when not in use.”

Carole says the apartment’s owners are “absolutely over the moon, as the space has met their expectations and more.”

[www.multispan.com.au](http://www.multispan.com.au)



1/  
XL900

# REDEFINING OUTDOOR LIVING

THE BRIEF WAS CLEAR: TO CREATE A COSY ENVIRONMENT IN AN OPEN, EXPOSED SPACE ON THE TERRACE OF A BRISBANE HIGH-RISE APARTMENT.







2/ BK5 + XL900

# TO INNOVATE AND INSPIRE

A NEW HOUSE, COMMERCIAL PREMISES – AND EVERYONE HAS THE SAME DILEMMA: WILL THE COLOUR SCHEME CREATE THE RIGHT AMBIENCE? WILL THE NEW PIECE OF FURNITURE WORK IN THE NEW ROOM? IT'S THE REASON WHY INTERIOR DESIGN GURU CARSTEN BATTERMAN HAS CREATED A PURPOSE-BUILT DESIGN STUDIO WHERE ARCHITECTS, INTERIOR DESIGNERS AND BUILDERS ALIKE CAN VISIT, SEE INNOVATIVE PRODUCTS IN SITU AND BE INSPIRED.

The Germany-based studio, STILHOF, has been built in Taufkirchen near Munich and provides 2,400m<sup>2</sup> showcasing the best in interior design, and providing unmatched variety in exclusive furniture. The studio revitalises a magnificent building previously used as horse stables in rural Germany, providing the idyllic backdrop for a relaxed and inspirational design experience.

“In creating STILHOF, we carefully selected partners which offer high-end, inspirational products. The studio provides settings which emulate a home or work or hospitality situation, and with different products on display, this allows ideas to cultivate further, offering alternatives that accentuate the product or room,” says interior designer Carsten, creator of STILHOF.

“It's really exciting helping customers and tradespeople not only take ideas to fruition, but go one step further to create amazing rooms beyond their expectations.”

#### Complementary, best in class

EcoSmart Fires sit comfortably in the STILHOF showroom, with the elite selection of 10 indoor and outdoor fires on display in a variety of settings.

“All products we have on display at offer class and versatility. Having a product that we are unable to display or only works for customers in certain situations is not part of the philosophy we have created STILHOF on,” comments Carsten.

Armed with a clear design vision, Carsten admits he was looking for a fitting fire element. “EcoSmart perfectly fitted with my designs – without huge adjustments. Sometimes it seems the burners were made just for me!”

“EcoSmart Fires were selected because they are state of the art, beautiful in design, have high functionality and are uncomplicated in installation – plus they're highly flexible to work with. In addition, the fires also provide compatibility with many of STILHOF's other products on display. The idea was to use fire to create a special atmosphere without having to undertake special building activities or install a chimney.”

#### Earthy elements

The EcoSmart Fires complement STILHOF's careful choice of materials, such as stone and stainless steel. The versatility of the EcoSmart range allows burners to be implemented as part of STILHOF's stone arrangements, or as a standalone display, such as an elegant flame housed between an architecturally designed stainless steel frame.

“Stone and fire fit perfectly,” Carsten adds. “We can say we are working with two of the original elements of earth history.

“The EcoSmart Fires literally light up the studio, and by having a selection of fires on display it demonstrates how the same can be created for any residential or commercial environment. I have installed an EcoSmart Fire in my own home, and I have clients – including high profile celebrities – who enjoy the ambience and warmth the EcoSmart Fires generate.

“Without the need for a flue or complicated licences, it means our clients enjoy the ease of use and can tailor EcoSmart Fires to suit their needs.”

Carsten describes the flame produced by the EcoSmart Fires as “very luscious, with a lovely, pleasant flame play.”

“All in all it is perfect to create a nice, warm atmosphere.”

In addition to installing EcoSmart Fires in the STILHOF studio and his own home, Carsten has installed fires in properties around Germany.

“We frequently recommend EcoSmart Fires; it's one of the reasons why we integrated them into our showroom. Of course they create a cosy, nice atmosphere, a place where our clients want to stay; plus they are a very good product to sell to people who want a living fire at home, but are unable to have a traditional fire.

“We are sure the demand for EcoSmart Fires will continue over the years because of the convincing concept of EcoSmart Fires, the high end designs and the flexibility.”

#### Pure distinction

The unique STILHOF concept demonstrates how best in class products can be brought together to offer the very best in interior design. The ideas that these carefully selected products and partners create ensure a design location from where distinction is born.

**“The EcoSmart Fires literally light up the studio, and by having a selection of fires on display it demonstrates how the same can be created for any residential or commercial environment.”**

CARSTEN BATTERMAN, STILHOF





# 3/ HOME SWEET HOME

THE FIRE COMPANY IS AN AUSTRALIAN  
COMPANY WITH FIRE IN ITS BELLY.

From the modest setting of a suburban warehouse in Sydney, Australia, in 2004, The Fire Company began distributing its creation, EcoSmart Fires, to five countries, then 22 countries, to the 75 that it is today. The rapid growth is testament to the company's vision, creativity and tenacity.

Having pioneered the global bioethanol fire 'revolution', it stands to reason that the creator of the award-winning EcoSmart Fire should lead the way with how its fires are showcased. With that in mind, EcoSmart Fire now has a new home, in Sydney's acclaimed design hub, Alexandria.

"Being able to display EcoSmart Fires in situ and in a way that demonstrates their quality and true potential was always the next step for us," says Stephane Thomas, director of The Fire Company. "Moving to Alexandria, closer to the CBD and amongst Sydney's design elite was the perfect move."

#### Attention to detail

In keeping with EcoSmart Fire style ethos, the company consulted top designer John Dimopoulos from Geoform Design Architects to create a purpose-built design studio and showroom fitting for its award winning products.

"Having also designed the freestanding fire Zeta, I understood the ideology of EcoSmart Fires and what the company wanted to achieve in a showroom. It was important to create a space that not only showcased the fires, but reflected the company's design ethic and attention to detail," says Dimopoulos.





“EcoSmart Fires are best displayed in controlled and dark environments, so the fires become the source of an ambient glow. But the space was unusually well lit, under a dramatic glazed sawtooth roof form. We responded to this by borrowing the zig-zag energy of the form and counter-balancing the brightness with darkness.

“The high-ceiling angled folded steel plates suggest a flickering and dancing of flames, hinting at the many layers of EcoSmart Fires subtly woven into the architectural expression of the space. The large scale of the room also enabled us to super-size elements such as the entrance desk.”

This desk is made up of 2.7 tonnes of steel and complemented by a high gloss floor providing a stunning entry point. Steel is also used for the concertina walls that create the display zones along the street frontage. Timber features widely, and has been used for the flooring, to ‘enclose’ the reception space, and for the floating cabinetry that sits behind the reception area, thus providing warmth and contrast between the steel and wood.

#### Design nucleus

The studio showcases the global company’s extensive EcoSmart Fire Collection — from freestanding fires to fireplace inserts, grates which easily convert existing fireplaces, to burners and the diverse range of outdoor fires. Simply put, designs to meet every taste or space.

**“Our design studio has become a hub for international visitors, local consumers and designers alike. It is a commercial environment for inspiration, consultation and education,”**

STEPHANE THOMAS, DIRECTOR

“Ultimately our design studio gives our customers confidence that they are making the right choice in ‘moving to modern’, based on seeing first-hand the products in operation, and that we understand what the flame can offer and how to best use EcoSmart Fire to achieve their own creative visions.” says Thomas.

[www.geoform.com.au](http://www.geoform.com.au)



4/  
BK5

# FIRE & WATER

MICORP IS A SYDNEY BUILDING COMPANY WITH A CLEAR OBJECTIVE – TO BUILD AND PROVIDE QUALITY HOMES AND RENOVATIONS WITH A PERSONALISED SERVICE THAT EXCEEDS EXPECTATIONS. NOT A DECLARATION TO BE MADE LIGHTLY, MICORP PRIDES ITSELF ON LISTENING TO CLIENTS TO TOGETHER CREATE BEAUTIFUL ARCHITECTURALLY-DESIGNED HOMES, RENOVATIONS OR LANDSCAPED GARDENS.

Con Mihas founded MiCorp Builders Pty Ltd in 1996 and transforms architectural dreams into reality. And as a builder, he practices what he preaches.

#### Seeing is believing

“I have worked with corporations, professionals and consumers on building projects for the last 20 years. If I could summarise what all customers want, it is a personalised service on time and to budget. And if they could see what they want to create before they build, they would do so every time,” says Con.

It's one of the reasons Con selected an EcoSmart Fire to install at his own home, for a stunning entrance statement and as a showpiece for customers to appreciate the dramatic effect of a fire in situ. The fire, set against a water falling sheet, combines the four elements of earth, water, air and fire to spectacular results.

“Water and fire are opposites that work brilliantly together. The structure has been built so I can alternate the focus from fire to water depending on the mood or season. Being able to showcase this fire to clients in this way, is just the start with clients eager to explore how they could emulate the same look and feel,” Con says.

#### Making a statement

Whether hosting a party or just a night with friends, a stunning entrance ‘sets the scene.’

“I love the fact that the fire makes a statement before anyone has set foot in the house. It's a great talking point and the feedback I've had has been overwhelmingly positive. It's the sort of feature people feel they have to comment on. It creates a lasting memory which clients love as well,” Con adds.

#### Seamless integration

Con used a BK5 burner built into a concrete floating bench with stainless steel features and finished with water plants. Working with elements such as fire and water meant everything needed to be assembled and built with pinpoint accuracy. The end result was a free-flowing water feature alongside a backdrop of mosaic tiles which flicker orange and yellow in the darkness behind the elegant flame.

“I have used EcoSmart Fires for clients in the past and was attracted to the way the fire can combine to dramatic effect with a water feature.

**The warmth of the fire and the bright light of a flickering flame draws people in, and creates a welcome environment for a drink and a chat – day or night,”**

CON MIHAS,  
MICORP BUILDERS PTY LTD

[www.micorp.com.au](http://www.micorp.com.au)





5/  
BK5

# THE NATURE OF FIRE

WHEN DESIGNING A CONTEMPORARY NEW SINGLE DWELLING FROM SCRATCH, ARCHITECTURAL AND INTERIOR DESIGN FIRM SAAJ DESIGN IN MELBOURNE WAS GIVEN CARTE BLANCHE TO CELEBRATE AS MANY DESIGN OPPORTUNITIES AS POSSIBLE, CREATING A HIGHLY PRIVATE HOME WITH STRONG CONNECTIONS TO THE EXTERIOR.

From the outset, a fireplace was an important element. But combining a wealth of organic materials with fire was always going to be a challenge.

**“Carved into recycled she-oak timber veneer and intersected with a suspended floating granite hearth, the EcoSmart Fire presents an ironic design element: fire burning within what appears to be a chopped section of a tree log.”**

SALLY ANDERSON,  
DIRECTOR OF SAAJ DESIGN

“We selected the EcoSmart Fire burner and used the principles of the Zeta fireplace as it gave us the ability to create an eco-friendly, ventless fireplace within an organic form adjacent to a timber material,” says Sally Anderson, director of SAAJ Design.

Situated on the living level of the new house which includes a sitting area, kitchen, scullery, powder room and a separate dining space, the customised EcoSmart Fire provides a stunning design statement. One end of the living space features a custom crafted she-oak timber side board and the other a she-oak timber wall which sweeps into an elliptical shaped cylinder holding the EcoSmart Fire stainless steel burner. Sally explains.

SAAJ Design worked closely with The Fire Company, Wilstruct the builder, the joiner and the furniture specialist, Damien Wright to customise the fireplace with its stainless steel surrounds and to combine it with the timber veneer format to create the shapes.

“The end result is extremely positive and the clients love the result,” says Sally. “The EcoSmart Fire burners are a great way to achieve the ambiance of fire within unique settings and we have since specified the product in a couple of other projects.”

[www.saaaj.com.au](http://www.saaaj.com.au)





6/

900DB

# MIXOLOGY MECCA FIRES UP BERLIN







IT'S DESCRIBED AS ONE OF BERLIN'S TOP 10 COCKTAIL BARS, AND THE SHOCHU IN BERLIN IS FAST BECOMING AS WELL KNOWN FOR ITS CLASSIC AND EXOTIC COCKTAILS AS IT IS FOR THE SLEEK AND SOPHISTICATED INTERIORS. LOCATED NEAR THE BRANDENBURG GATE, IN THE ADLON HOTEL AND ADJACENT TO THE RENOWNED UMA RESTAURANT, SHOCHU WAS CREATED BY ACCLAIMED DESIGNER ANNE MARIA JAGDFELD.

Anne Maria is known for her distinctive and exquisite taste when it comes to interior design. Her style is genuine luxury that is subtle and relaxed with a focus on high quality materials, first class workmanship and a matchless combination of classic shapes and modern design. And the Shochu Bar is testament to this unique style.

In the words of Martina Rink, fashion guru and fashion director of Mode magazine, Anne Maria "has given the Shochu a desirable living room atmosphere."

Helping create this atmosphere is the specially built, double-sided EcoSmart fireplace which takes pride of place at the heart of Shochu. To create the centrepiece, Anne Maria used an EcoSmart 900DB firebox set into a timber-panelled pylon with a toughened glass screen.

"The fireplace is an important component in the design of the bar. It is located in the centre of the bar, a special part of the restaurant," Anne Maria says. "It builds the visual focus when you approach the room and is the centre of attention.

"The firebox 900DB has a simple and elegant design and a double opening, which enables the fire to be seen from around the room."

Anne Maria has created an interior infused with elegance, combining Asian furnishings and antique wall coverings. "The simplicity of the firebox fits this perfectly," she says.

"The design of the fire is modern and simple but it still offers the comfort of a traditional fireplace and provides atmospheric warmth and comfort."

The fire and its unique setting perfectly complement the dark wood, leather, slate and chocolate colour scheme, not to mention the illuminated glass catwalk which leads into the bar. Comfortable sofas and plush stools further enhance the warmth of the space.

**"The fireplace is an important component in the design of the bar. It builds the visual focus when you approach the room and is the centre of attention."**

ANNE MARIA JAGDFELD, DESIGNER

The environmental credentials of the EcoSmart Fire also influenced Anne Maria's decision in using the product. "We hope to use EcoSmart Fire again in one of our hotel projects," she says. "There's a great spectrum of models."

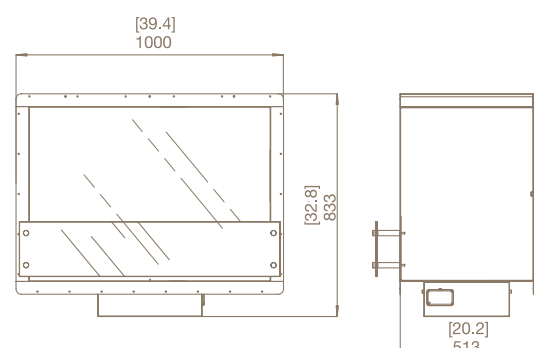





# 7/ XL900 ICONIC ARCS

THE ICONIC OUTDOOR AMPHITHEATRE THE HOLLYWOOD BOWL IN LOS ANGELES IS AS RENOWNED FOR ITS LIVE PERFORMANCES AS IT IS FOR ITS ARCHITECTURE – A ‘BAND SHELL’ COMPRISED OF A DISTINCTIVE SET OF CONCENTRIC ARCHES. IT WAS ALSO THE KEY DRIVER FOR A THIRD GENERATION SOUTHERN CALIFORNIAN RESIDENT WHO WANTED TO TRANSFORM HER BACKYARD.

Enter LA-based designer Daniel Vandembark, founder and principal of DEZINE, Inc, a firm that specialises in interior and exterior design.

“I was hired to create a contemporary deco garden that is easy to maintain and that could be transformed for dancing, barbecues and wine,” Daniel explains.

Daniel is in the unique position of being an EcoSmart Fire dealer, which he has been doing for over seven years. “In my design work I enjoy specifying EcoSmart Fire because of its flexibility and suitability for an array of designs,” he says. “For this Hollywood project, my client already knew about EcoSmart Fire, so it was a very easy sell!”

Daniel explains that the design of the fire was inspired by the Hollywood Bowl, which is located close to the home. The concept was to have an arc ‘suspended’ over an XL900 burner, similar to the arches of the Hollywood Bowl.

“Deco style has been highly influential in Hollywood,” Daniel explains. “Initially we envisioned the arc in concrete, but there were a number of obstacles to achieving this, so I suggested metal. It took my metal fabricator and me a number of hours, and many iterations to come up with a viable solution and get the right fit.

“The idea was for the stainless steel to be as uninterrupted as possible and appear as though

it was ‘floating’. Because of the small space, I wanted as much floor space visible as possible to help create the illusion of more space.”

That solution was delivered in the juxtaposition of the cantilevered concrete base to hold the XL900 and completed by the stainless steel arch. “We meticulously measured the ideal arch and created a custom mount to allow that arch to hover with minimal interruption from any vantage point in the garden,” says Daniel.

The ends are allowed to seemingly disappear with the fire-tempered glass, while mimicking the curve of the stainless steel.

“I was so nervous with the installation, as the design was such that even a quarter of an inch of error in any detail, it would be completely visible from anywhere in the garden. But it all went exactly as I hoped it would. It was a perfect installation,” Daniel says.

“The metal arc ensures a beautiful fire with a long, tall flame that glows off the stainless steel. With the XL900 burner you get such a big, full flame.”

Daniel’s signature style has been described as bohemian-eclectic and modern-timeless. He focuses on creating “spiritual environments”, and fire often plays a key role. “Fire is innately spiritual and brings light and spirituality into a space,” Daniel says.

Over the past 12 years, Daniel’s design work has taken him from Southern California to Denver to Houston and New York, and as far as Berlin, Germany and Chamonix, France.

DEZINE’S eco-showroom makes available a wide range of products, including EcoSmart Fire. “We believe in quality, period,” Daniel says. “Aligning ourselves with brands committed to excellence is what makes our job beautiful.”

[www.dezine.com](http://www.dezine.com)



8/  
XL900

# MOVING TO MODERN

ECOSMART FIRE BREATHES NEW LIFE INTO  
ACCLAIMED ART DECO FIREPLACE

Celebrating its 80th anniversary this year, the magnificent Manchester Unity Building has a special place in the history of Melbourne and the hearts of its citizens. So when Dr Kia Pajouhesh, managing director and principal dentist of Melbourne-based Smile Solutions and Chairman of the MUB Owner's Corporation, took on the task of restoring this building to its original beauty, it was the beginning of a labour of love.

The building's boardroom is considered to be the most intact Art Deco Boardroom anywhere in the world. It carries a separate heritage listing to the rest of the building, and far from being a

redundant showpiece, it is a functioning boardroom.

"In many ways the boardroom is the jewel in the crown and offered us an opportunity to not only restore it to its original splendour, but to rejuvenate an aesthetically beautiful and authentic room," explains Dr Pajouhesh.

#### Recreating the fireplace

The boardroom restoration was made easier by a number of features, such as the stunning fireplace, remaining intact and the boardroom table in situ – primarily because previous developers were unable to move the almost six metre Queensland maple cross-banded with rosewood table.

The magnificent fireplace occupies a distinct nook in the boardroom and was originally built as a decorative feature without a chimney or any other means of extraction. The fireplace consists of an interior of white polished marble tiles, a mantel of carved marble and a hearth of contracting pink veined marble. The grate and decorative glass stones were disposed of and a granite platform was installed. The only element missing was an actual fire.

The challenge was to find a live-burn fire system that could work within the physical constraints of the room and not challenge the heritage overlays.

An EcoSmart Fire was chosen because of its clean burn system and because it provides a vibrant flame without the need for fluing. The XL900 burner perfectly fitted the 1500mm fireplace opening and produces an animated flame that scales perfectly within a large fireplace setting.

A passionate collector of Art Deco, Dr Pajouhesh had the perfect centrepiece for his fire – a hand crafted bronze spelter, bronze sculpture of *Warrior Confronting Beast* (circa 1932), the year the Manchester Unity building came to life.

The fireplace and bronze sculpture are situated below a display of religious icons to provide a 'symbolism of life.' A polished black granite plinth was custom made to provide the platform for the 'struggle' of man versus beast, and a structure for the EcoSmart Burner discreetly inlaid into the stone behind the sculpture.

The installation of the burner was simple, and the result is an interplay between the two key elements that is both effective and dramatic.





9/  
XL700

# HOME AWAY FROM HOME

THE PREMISE IS TO PROVIDE THE CREATURE COMFORTS OF A PERMANENT RESIDENCE AND THE AMENITIES OF A HIGH-END HOTEL IN ONE PACKAGE – AND THE AKA SUTTON PLACE IN NEW YORK CERTAINLY DOESN'T DISAPPOINT. THE BOUTIQUE PROPERTY, DESIGNED FOR EXTENDED STAYS, OFFERS ITS GUESTS ALL-INCLUSIVE AMENITIES, INCLUDING THE STRIKING A.LOUNGE, A PLACE WHERE RESIDENTS CAN RELAX AND ENJOY COFFEE AND PASTRIES IN THE MORNING AND WINE AND COCKTAILS IN THE EVENING.

Designed by acclaimed design house Meyer Davis Studio, known for celebrated NYC restaurants Locanda Verde and Boqueria as well as noteworthy hospitality and residential projects around the US, the a.lounge has been created to artfully complement Sutton Place's traditional warmth with a relaxing ambiance. And at its heart is a carefully considered and placed open fireplace.

"The fireplace is the center element of the lounge, creating a focal point that divides the seating groups," explains Meaghan Wren from Meyer Davis Studio. "It's the feature that can be seen from all areas of the space and enhances the warmth of the walnut panelled room."

Meaghan admits it was very important to have an open fire in the lounge. "We love the sense of comfort a fireplace gives," she says. "To have a fireplace in a hotel where most guests stay for weeks and months at a time helps provide a 'home away from home' feeling."

Given that many places in New York City are not equipped to have a fireplace because of ventilation issues, the Meyer Davis team discovered EcoSmart Fire while researching ventless options. The environmental aspect of using the bioethanol-fuelled EcoSmart Fire was another deciding factor for the design team.

"We love the modern look of the EcoSmart products," Meaghan says. "The ventless aspect of the system is important because we are able to use them in places where ventilation is not possible. "We did not choose this product as a heat source but as an aesthetic design element to enhance our overall concept." For the a.lounge, the XL700 burner has been incorporated into a setting with marble top – a design element that's consistent with the lounge's stunning marble bar – and is surrounded by blackened steel on two sides and above.

**"The fireplace is the center element of the lounge, creating a focal point that divides the seating groups. It's the feature that can be seen from all areas of the space and enhances the warmth of the walnut panelled room."**

MEAGHAN WREN – MEYER DAVIS STUDIO

"We wanted the space to feel relevant to its location. We looked at the traditional and upscale neighbourhood, Sutton Place, and put a modern twist to the style with materials, furniture and lighting," adds Meaghan.

No stranger to EcoSmart Fire, Meyer Davis Studio has previously used EcoSmart Fires in residential, restaurant and hotel projects. "And we have already specified EcoSmart fireplaces for projects currently being designed," Meaghan adds.

[www.meyerdavis.com](http://www.meyerdavis.com)









# 10/ XL700 A PORTRAIT OF LIFE

DESIGN PROFESSIONAL SUSAN JAY HAS A SIMPLE DESIGN PHILOSOPHY: "I BELIEVE MY CLIENTS' LIFESTYLE DICTATES THE DESIGN," SHE SAYS. "THE DESIGN IS A PORTRAIT OF THEIR LIFESTYLE."



It's with this in mind that Susan, principal of Susan Jay Design in Los Angeles, created an amazing piece of fine furniture in the master bedroom of a Southern Californian home. "It was derived from my clients' desire to view the television and fireplace from their bed," Susan explains.

Initially Susan's clients wanted a wood fireplace, but due to a number of reasons – including building codes – this wasn't possible, and Susan presented them with the option of an EcoSmart Fire.

"I am a big fan of EcoSmart Fire and believe in their products," she says. "I find EcoSmart the easiest to work with and the most beautiful."

Keeping in line with the design of the home, which Susan describes as having a mid-Century modern vibe, she worked closely with artisan Corey Springer from New York's acclaimed Wüd Furniture Design to come up with a concept.

"I wanted a cabinet that wouldn't bring attention to the firebox, but that would integrate into the room,"

Susan says. "We wanted a piece of furniture which was both lovely to look at and which would have function."

The result is a custom-made, suspended cabinet which incorporates the stainless steel firebox with XL700 burner. "I chose a firebox which would have the right size and configuration. With this model, you can build around it, plus the longer flame fitted the profile of this project."

Susan also wanted colour and visual texture, and Corey suggested rich-hued

Australian Walnut – a non-endangered timber – for the cabinetry. Corey then created a lacquer top to further enhance the tones. To ensure consistency, Australian Walnut was also used for the custom-made bed and nightstands. "I love the markings and colour of the wood," Susan says.

And to subtly lift the colour of the cabinet even more, coloured glass rocks were placed in the area surrounding the stainless steel burner.

"Another objective was to have visual interest; something that wasn't

completely symmetrical," Susan adds. "It's why the left side compartment of the cabinet is open and the right side is closed." The left side serves as a bookshelf, while the right compartment creates storage for the fire starter tool along with an extra bottle of bioethanol."

The cabinet was made in New York by Wüd Furniture Design and then transported to Los Angeles. "The installation was brilliant, very simple," adds Susan.

[www.susanjaydesign.com](http://www.susanjaydesign.com)  
[www.wudfurniture.com](http://www.wudfurniture.com)



# SETTING THE BENCHMARK

Established in 2002, The Fire Company is an Australian design, innovation and export success story. Its ground-breaking range of eco-friendly bioethanol fireplaces, burners and accessories can now be found in 55 countries worldwide, across a diverse range of architectural environments.

Since its inception, The Fire Company has been at the forefront of innovation and continues to set benchmarks in design, originality, safety and sustainability. The Fire Company has pioneered the evolution of the now well-established international bioethanol fireplace industry and has led the creation of global standards and testing platforms.

As the industry becomes more regulated, EcoSmart Fire is dedicated to the ongoing support and guidance in the creation of standards and to complying with these regulatory requirements.

Bioethanol fireplaces are classified by regulations and standards as decorative fireplace appliances. Copies of test results are available to qualified applicants.

## SAFETY FIRST

Mixing fire, dangerous goods and human beings is a serious business, and something we take very seriously.

As one of the first brands of "Unvented alcohol fuel burning decorative appliances" in what is now a vastly competitive global market, our award winning collection continues to set benchmarks in many arenas - from the quality of manufacturing, to the operational system and built in safety features, through to the certification achieved from various testing bodies around the world, the EcoSmart™ Fire is ever at the forefront of design, technology and safety.

EcoSmart Fires are accompanied by a proprietary operational system that ensures the safe operation of the product. Every aspect from decanting the fuel, lighting the flame, regulating the flame to extinguishing the flame has been thought through and accessorised in order to control the method of operation. As the most independently tested product on the market we offer peace of mind and have an excellent safety record.

## AWARD WINNING

EcoSmart Fires were launched onto the global stage in 2004 and in the same year were awarded an Australian Design Mark. Since then, our accolades have expanded to include:

- 2011 IIDA/HD Award for Excellence (USA)
- 2011 DesignEx Best New Product (AUS)
- 2011 FINALIST Australian International Design Awards (AUS)
- 2010 International Hotel, Motel + Restaurant Show, New York
- 2010 Editor's Choice Award for Best New Product - Green Design (USA)
- 2009 Australian International Design Award (AUS)



## XL900



ECOSMART'S BURNERS ARE BEHIND MANY OF THE 'ON-TREND' STYLES THAT ARE APPEARING AROUND THE WORLD. AND INCREASINGLY, THE BURNERS ARE BEING USED IN DISTINCTIVE, OFTEN ARTISTIC, WAYS.

The XL Series of stainless steel burners, in particular, continues to inspire original creations both indoors and outdoors - from suspended cabinets and floating benches, combined water/fire features, to see-through pillars with the open fire at its heart. Three sizes - XL500, XL700 and XL900 - enable design professionals to create an elongated, or 'stretched' flame, satisfying the demand from designers, builders, developers and consumers alike.

## E-NRG - IT'S NATURAL, RENEWABLE, GREEN.

Bioethanol comes in many different brands and blends. Where available we recommend e-nrg.

E-NRG produces a beautiful, vibrant flame that burns longer and cleaner - and for your convenience it's available online.

Fire up your EcoSmart Fire with the best, cleanest bioethanol available.

[www.e-nrg.com](http://www.e-nrg.com) [www.e-nrg.com.au](http://www.e-nrg.com.au)



## HEAD OFFICE

Showrooms 3 & 4, 40-42 O'Riordan Street  
Alexandria NSW 2015 Australia  
Ph +61 2 9997 3050 [info@ecosmartfire.com](mailto:info@ecosmartfire.com)

## USA SHOWROOM

EcoSmart Inc. 3641 Holdrege Avenue, Suite B,  
Los Angeles, CA 90016 USA  
Ph +1 (310) 945 3335 [info@ecosmartfire.com](mailto:info@ecosmartfire.com)

## PRODUCT INFORMATION & CUSTOMER SERVICE

Contact our Customer Service Team for information about any of our products, including technical questions and pricing enquiries. [info@ecosmartfire.com](mailto:info@ecosmartfire.com)

## COMMERCIAL & MULTI-UNIT ENQUIRIES

Contact our Commercial Sales Division to learn how to incorporate EcoSmart Fire into your next large scale development. [specify@ecosmartfire.com](mailto:specify@ecosmartfire.com)

## MEDIA ENQUIRIES

For access to our library of press releases and high resolution imagery, you can request access to our document library, or information from our media representative. [media@ecosmartfire.com](mailto:media@ecosmartfire.com)



