

DISCOVER THE FIREPLACE OF YOUR DREAMS!

# TECHNICAL SPECIFICATIONS

## BIO ETHANOL FIRES

ELEMENT





## A FIREPLACE THAT MATCHES YOUR DNA

"At Element4 we have a clear ambition: to make the impossible come true. We love to think outside of the box. This results in a wide range of innovative fireplaces with powerful designs and beautiful flame pictures. It is precisely this combination that ensures that our brand is loved worldwide by design enthusiasts and architects alike.

Our promise? A fireplace with great features that will enhance any interior. We hope that this brochure will convince you of that too."

**Jan Kempers**  
CEO and Founder

# TABLE OF CONTENTS

Fireplace	Specifications
Bio Ethanol fire Stove	
<b>BIO 50I</b>	<b>PAGE 4</b>
Bio Ethanol fire Front	
<b>SKY SMALL FRONT BIO</b>	<b>PAGE 5</b>
<b>SKY MEDIUM FRONT BIO</b>	<b>PAGE 6</b>
<b>SKY LARGE FRONT BIO</b>	<b>PAGE 7</b>
Bio Ethanol fire See-through	
<b>SKY SMALL TUNNEL BIO</b>	<b>PAGE 8</b>
<b>SKY MEDIUM TUNNEL BIO</b>	<b>PAGE 9</b>
<b>SKY LARGE TUNNEL BIO</b>	<b>PAGE 10</b>
Bio Ethanol fire Room divider	
<b>SKY SMALL ROOMDIVIDER BIO</b>	<b>PAGE 11</b>
<b>SKY MEDIUM ROOMDIVIDER BIO</b>	<b>PAGE 12</b>
<b>SKY LARGE ROOMDIVIDER BIO</b>	<b>PAGE 13</b>



Bio Ethanol fire

# BIO 50I

Bio-Ethanol burner

Net natural Bio Ethanol capacity (min-max): 5-7 kW

Energy efficiency class: A++

Remote control: (Standard)

Access door: (Optional)

Convection grills built-in and surface-mounted: (Optional)

## BIO 50I

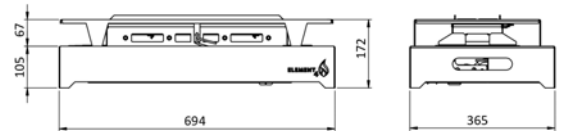
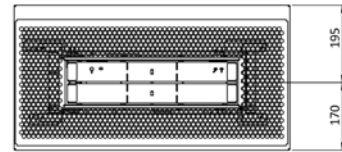
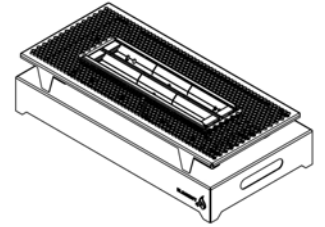

ELEMENT 



Bio Ethanol fire

## SKY SMALL FRONT BIO

Bio-Ethanol burner

Net natural Bio Ethanol capacity (min-max): 5-7 kW

Energy efficiency class: A+

Black steel: (Standard)

Black reflective panels: (Optional)

Remote control: (Standard)

Powerfan: (Optional)

Anti-reflective glass: (Optional)

Access door: (Optional)

Convection grills built-in and surface-mounted: (Optional)

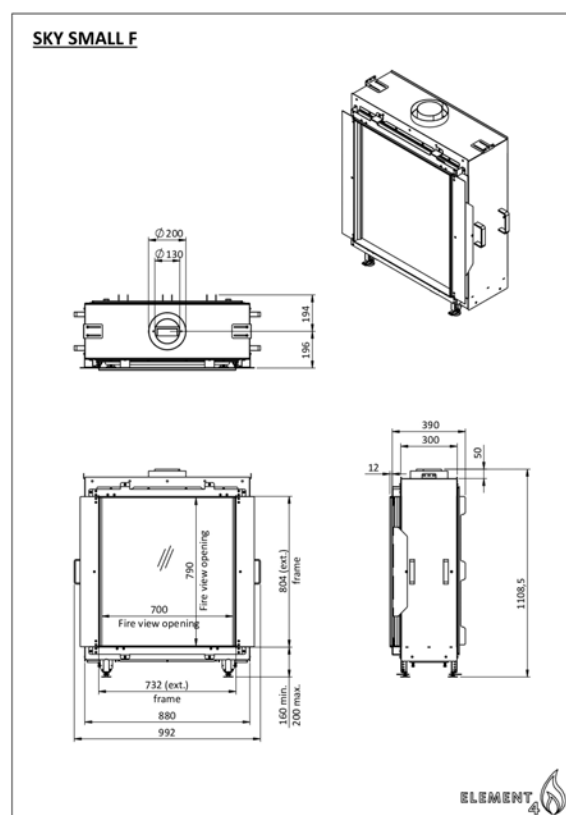



Bio Ethanol fire

## SKY MEDIUM FRONT BIO

Bio-Ethanol burner

Net natural Bio Ethanol capacity (min-max): 5-7 kW

Energy efficiency class: A+

Remote control: (Standard)

Powerfan: (Optional)

Anti-reflective glass: (Optional)

Access door: (Optional)

Convection grills built-in and surface-mounted: (Optional)

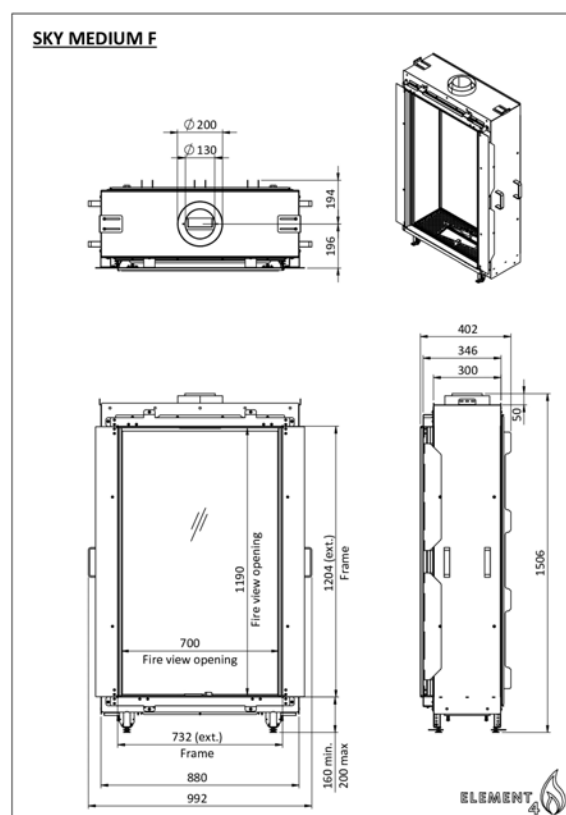



Bio Ethanol fire

# SKY LARGE FRONT BIO

Bio-Ethanol burner	
Net natural Bio Ethanol capacity (min-max):	5-7 kW
Energy efficiency class:	A+
Black steel:	(Standard)
Black reflective panels:	(Optional)
Remote control:	(Standard)
Powerfan:	(Optional)
Anti-reflective glass:	(Optional)
Access door:	(Optional)
Convection grills built-in and surface-mounted:	(Optional)

## SKY LARGE F

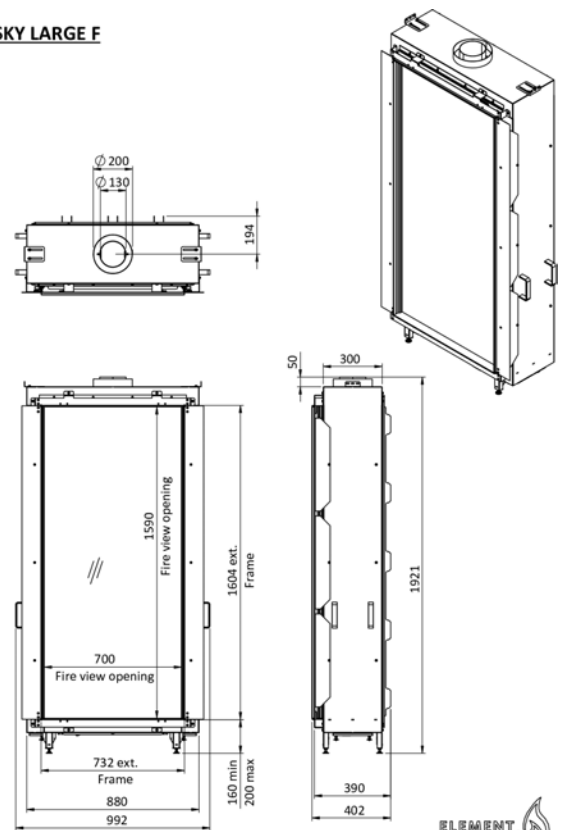



Bio Ethanol fire

## SKY SMALL TUNNEL BIO

Bio-Ethanol burner

Net natural Bio Ethanol capacity (min-max): 5-7 kW

Energy efficiency class: A+

Black steel: (Standard)

Black reflective panels: (Optional)

Remote control: (Standard)

Powerfan: (Optional)

Anti-reflective glass: (Optional)

Access door: (Optional)

Convection grills built-in and surface-mounted: (Optional)

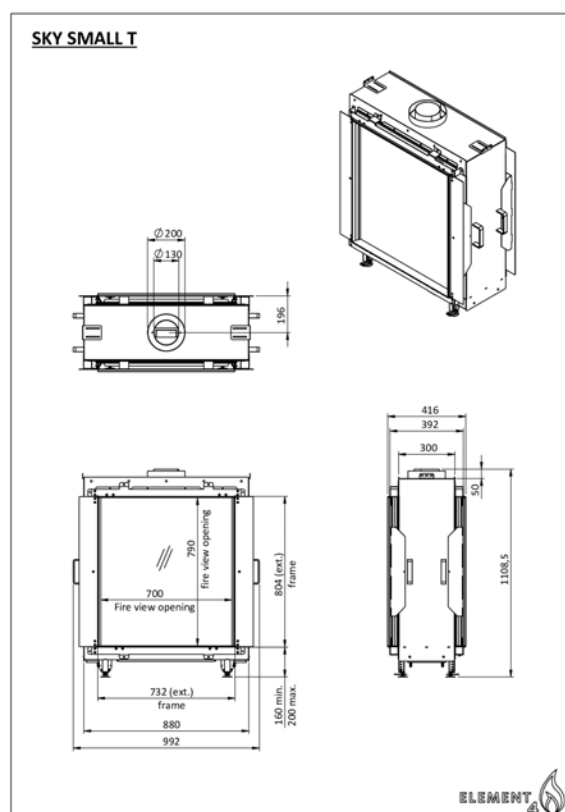





Bio Ethanol fire

# SKY MEDIUM TUNNEL BIO

Bio-Ethanol burner	
Net natural Bio Ethanol capacity (min-max):	5-7 kW
Energy efficiency class:	A+
Black steel:	(Standard)
Black reflective panels:	(Optional)
Remote control:	(Standard)
Powerfan:	(Optional)
Anti-reflective glass:	(Optional)
Access door:	(Optional)
Convection grills built-in and surface-mounted:	(Optional)

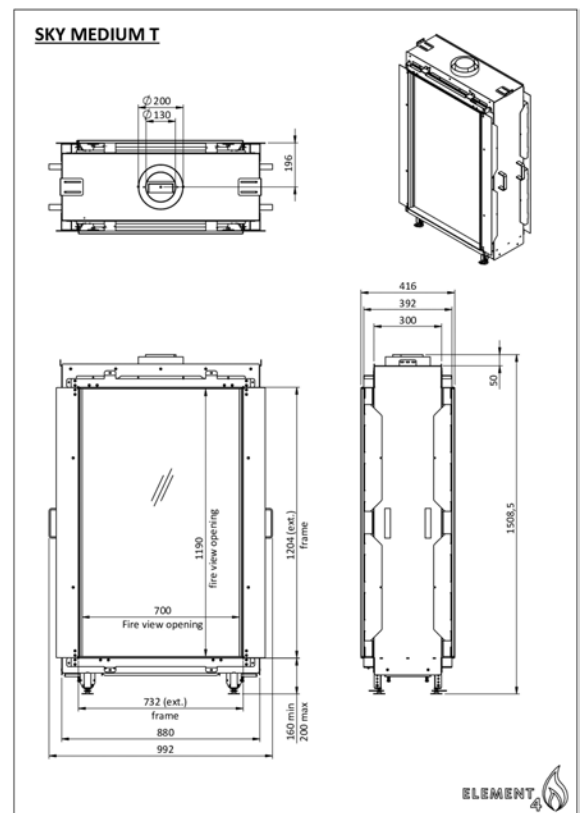



Bio Ethanol fire

# SKY LARGE TUNNEL BIO

Bio-Ethanol burner	
Net natural Bio Ethanol capacity (min-max):	5-7 kW
Energy efficiency class:	A+
Black steel:	(Standard)
Black reflective panels:	(Optional)
Remote control:	(Standard)
Powerfan:	(Optional)
Anti-reflective glass:	(Optional)
Access door:	(Optional)
Convection grills built-in and surface-mounted:	(Optional)

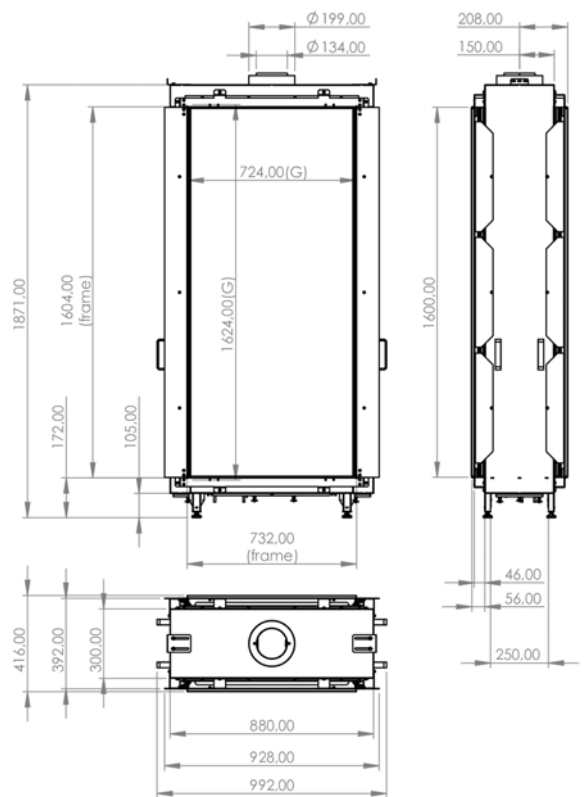



Bio Ethanol fire

## SKY SMALL ROOMDIVIDER BIO

Bio-Ethanol burner

Net natural Bio Ethanol capacity (min-max): 5-7 kW

Energy efficiency class: A+

Black steel: (Standard)

Black reflective panels: (Optional)

Remote control: (Standard)

Powerfan: (Optional)

Anti-reflective glass: (Optional)

Access door: (Optional)

Convection grills built-in and surface-mounted: (Optional)

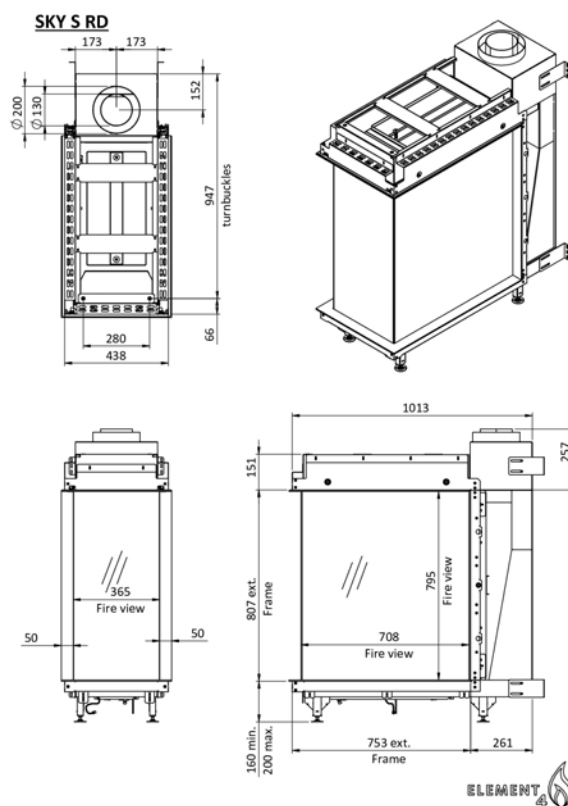



Bio Ethanol fire

# SKY MEDIUM ROOMDIVIDER

## BIO

Bio-Ethanol burner

Net natural Bio Ethanol capacity (min-max): 5-7 kW

Energy efficiency class: A+

Black steel: (Standard)

Black reflective panels: (Optional)

Remote control: (Standard)

Powerfan: (Optional)

Anti-reflective glass: (Optional)

Access door: (Optional)

Convection grills built-in and surface-mounted: (Optional)

SKY M RD

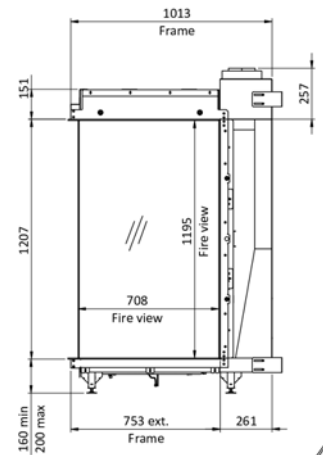
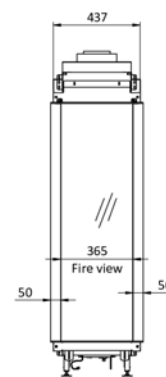
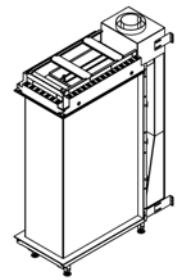
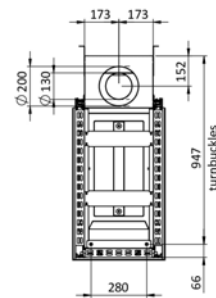

ELEMENT 



Bio Ethanol fire

# SKY LARGE ROOMDIVIDER BIO

Bio-Ethanol burner	
Net natural Bio Ethanol capacity (min-max):	5-7 kW
Energy efficiency class:	A+
Black steel:	(Standard)
Black reflective panels:	(Optional)
Remote control:	(Standard)
Powerfan:	(Optional)
Anti-reflective glass:	(Optional)
Access door:	(Optional)
Convection grills built-in and surface-mounted:	(Optional)

SKY L RD

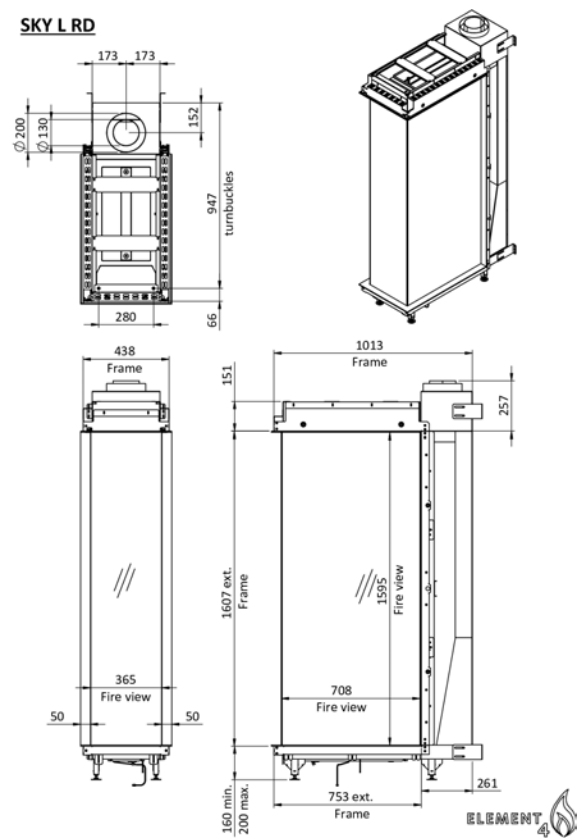

**AN EXTRAORDINARY INTERIOR NEEDS A  
FIREPLACE FROM ELEMENT4**



**ELEMENT**  
**4** 

